



(19) **United States**

(12) **Patent Application Publication**

Taylor et al.

(10) **Pub. No.: US 2017/0041990 A1**

(43) **Pub. Date: Feb. 9, 2017**

(54) **METHODS FOR PRODUCING A GLASS-BASED NON PLANAR DIGITAL DISPLAY**

H01L 51/00 (2006.01)
H05B 33/08 (2006.01)
H01L 27/32 (2006.01)

(71) Applicant: **Microsoft Technology Licensing, LLC**, Redmond, WA (US)

(52) **U.S. Cl.**
CPC *H05B 33/04* (2013.01); *H05B 33/0896* (2013.01); *H01L 27/3251* (2013.01); *H01L 51/0096* (2013.01); *H01L 51/5237* (2013.01); *G02F 1/1339* (2013.01)

(72) Inventors: **Joseph Taylor**, Seattle, WA (US);
Cynthia Sue Bell, Kirkland, WA (US);
Rod G. Fleck, Bellevue, WA (US);
Kshitij Moghe, Issaquah, WA (US);
Paul O'Brien, Sammamish, WA (US)

(73) Assignee: **Microsoft Technology Licensing, LLC**, Redmond, WA (US)

(57) **ABSTRACT**

(21) Appl. No.: **15/277,775**

(22) Filed: **Sep. 27, 2016**

A curved display for an electronic device, comprises a main substrate, a display circuit component, an OLED stack and a secondary substrate. The main substrate has a first curved section extending from a first end of the main substrate and a longitudinally adjacent second planar section extending to define a second end of the main substrate opposite the first end. The first curved section comprises at least one flat glass member bent into a curved configuration, and the second planar section comprises a flat segment of the flat glass member. The display circuit component is mounted to an upper surface of the second planar section, the display circuit component being positioned within and spaced from edges of the second planar section. The OLED stack is positioned over the first curved section. The secondary substrate comprises a flat glass member bent into a curved configuration and secured to the first curved section of the main substrate with the OLED stack positioned between the first curved section of the main substrate and the secondary substrate.

Related U.S. Application Data

(63) Continuation of application No. 13/944,834, filed on Jul. 17, 2013, now Pat. No. 9,470,919.

(60) Provisional application No. 61/823,332, filed on May 14, 2013.

Publication Classification

(51) **Int. Cl.**
H05B 33/04 (2006.01)
H01L 51/52 (2006.01)

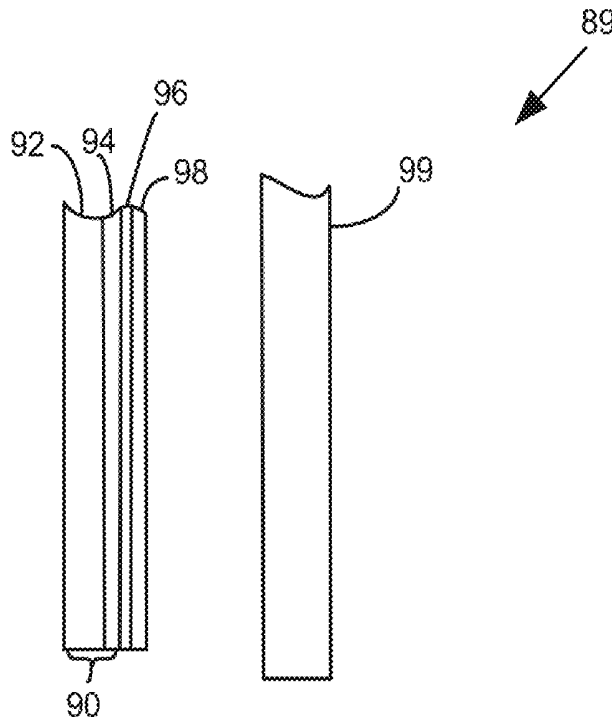

FIG. 1

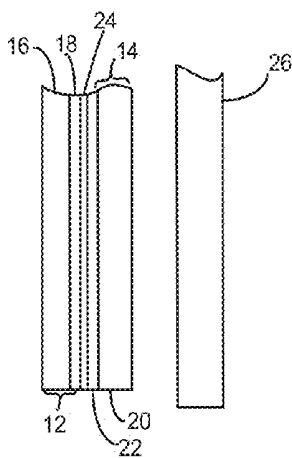

FIG. 2

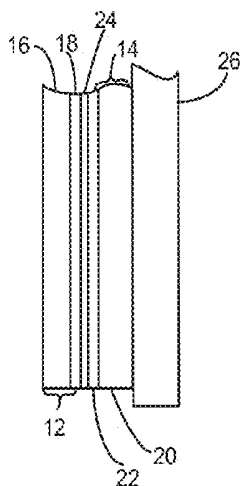
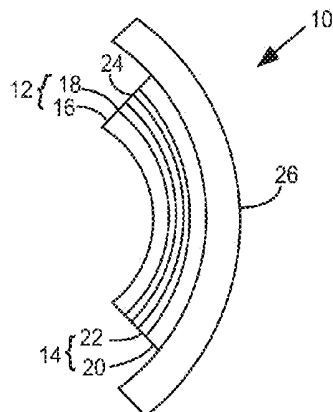

FIG. 3



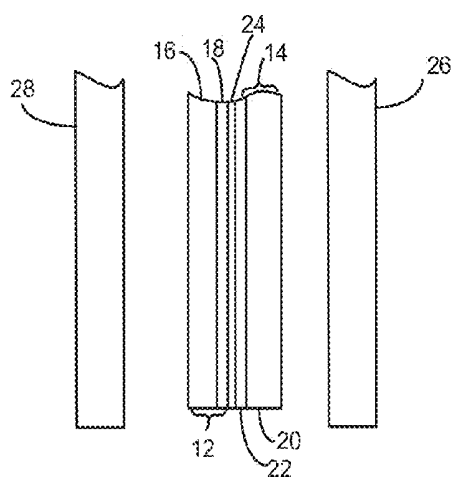

FIG. 4

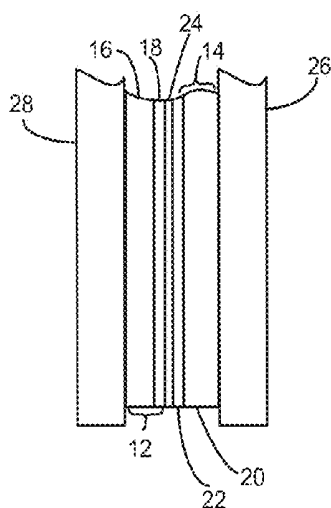

FIG. 5

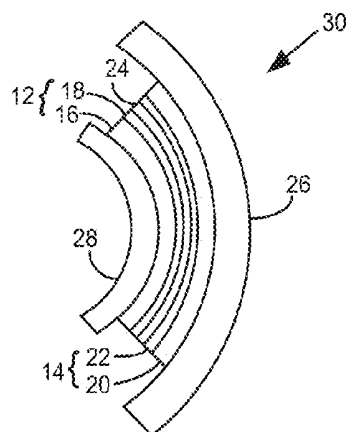

FIG. 6

FIG. 7A

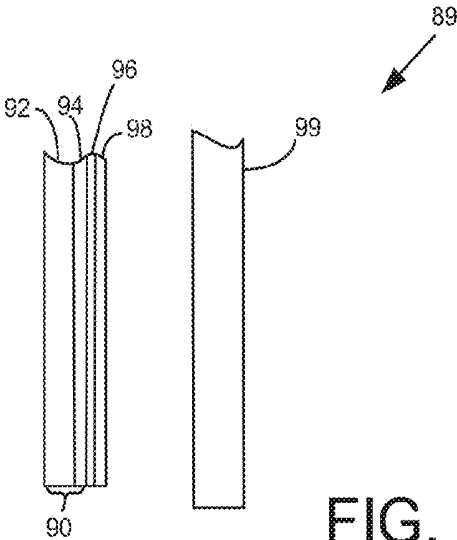
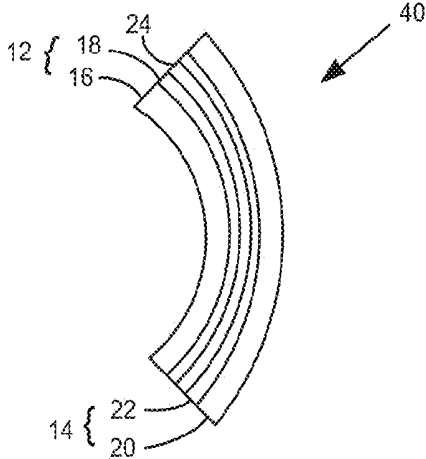

FIG. 7B

FIG. 8

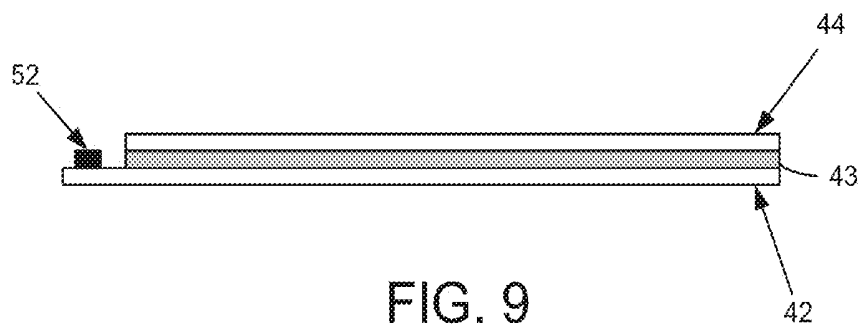
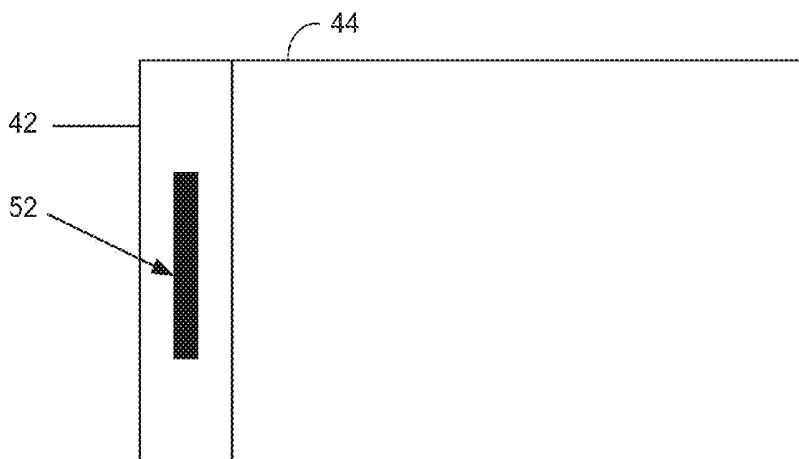

FIG. 9

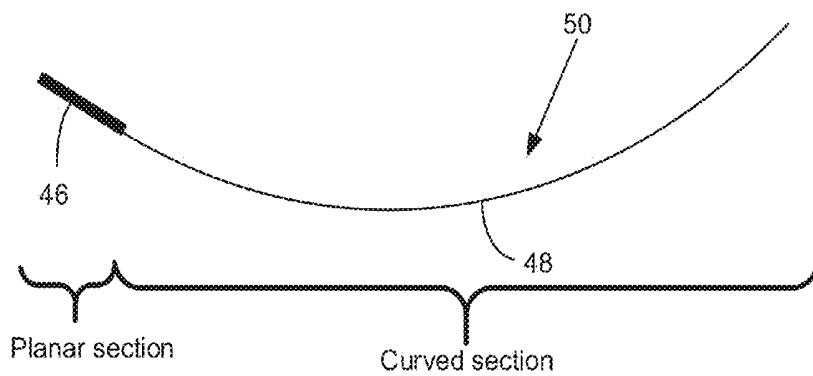

FIG. 10

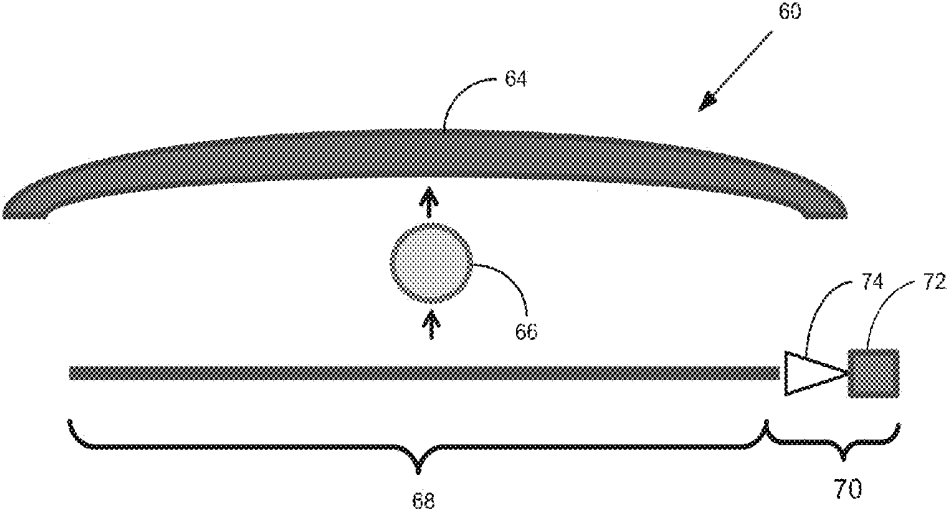

FIG. 11

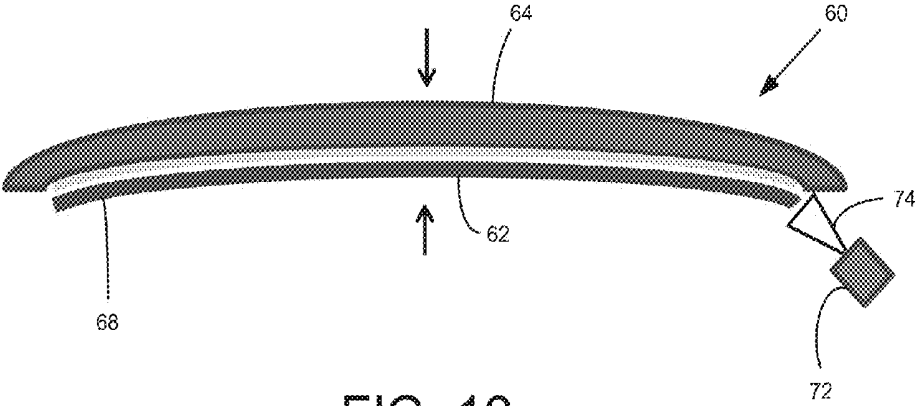

FIG. 12

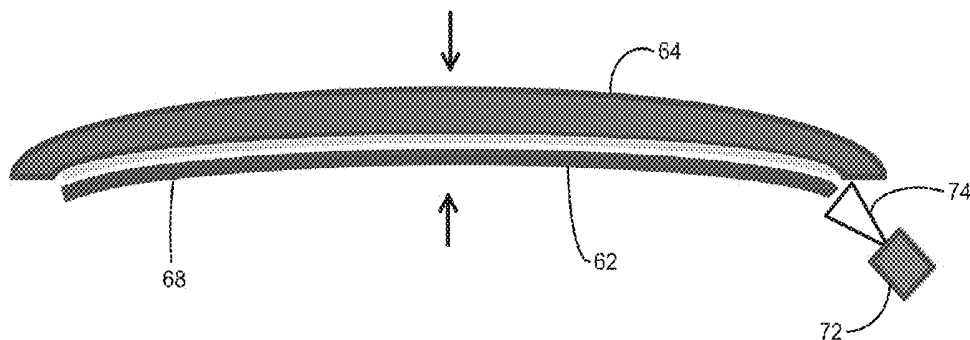
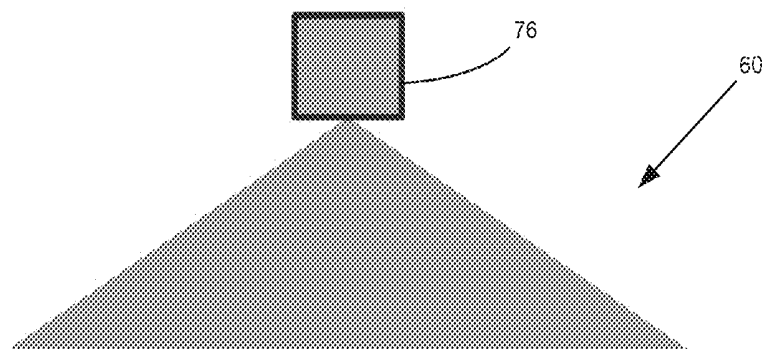

FIG. 13

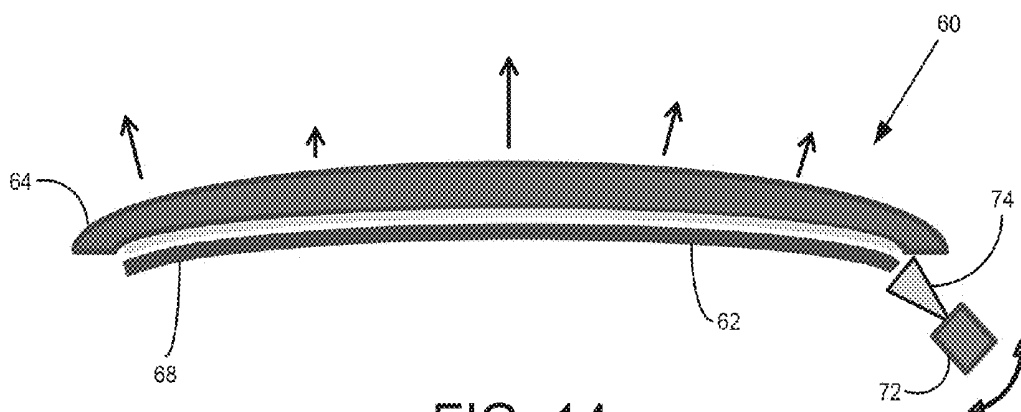

FIG. 14

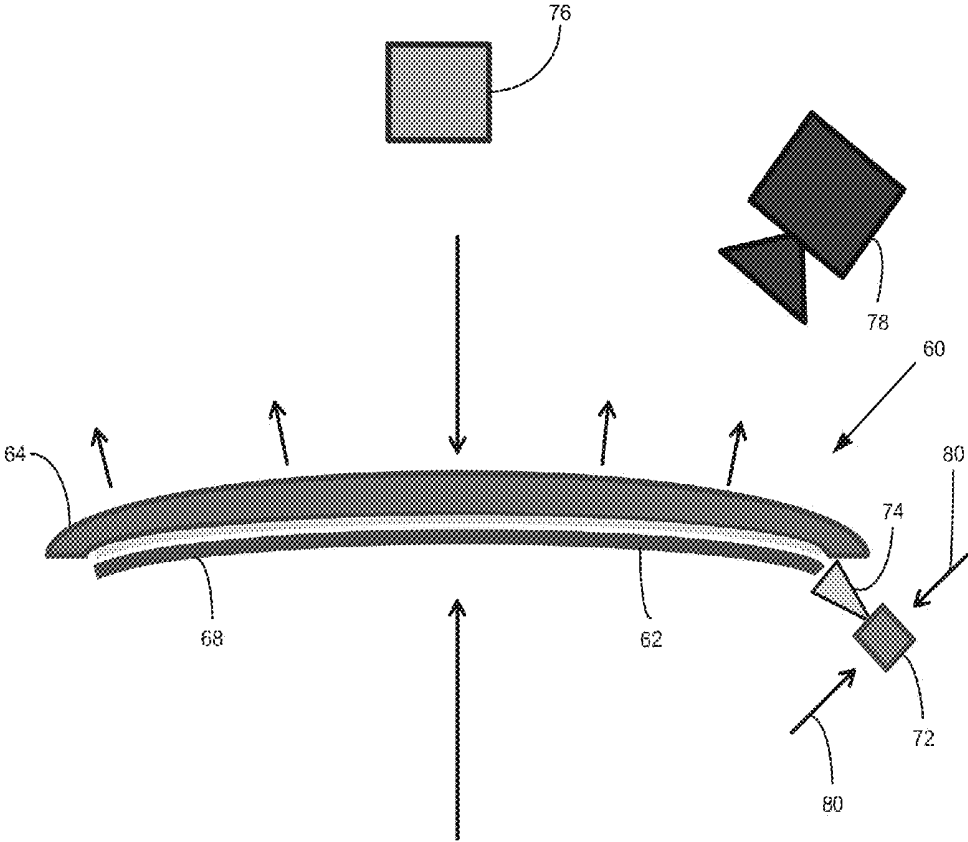

FIG. 15

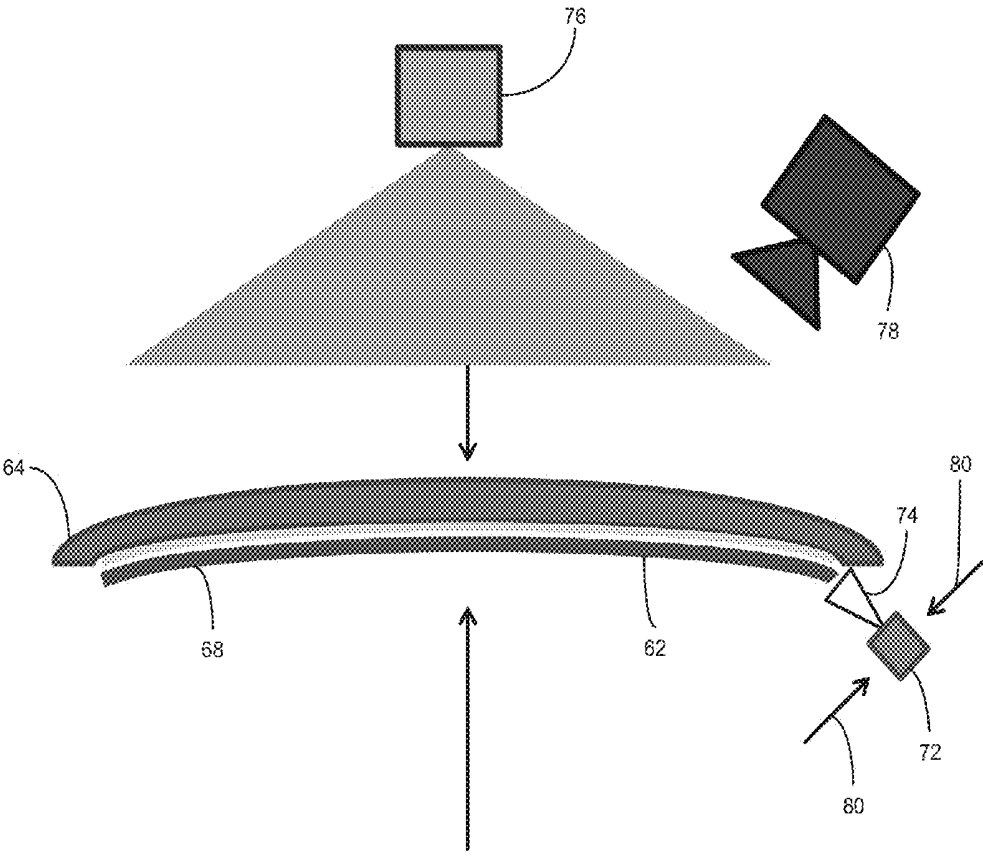

FIG. 16

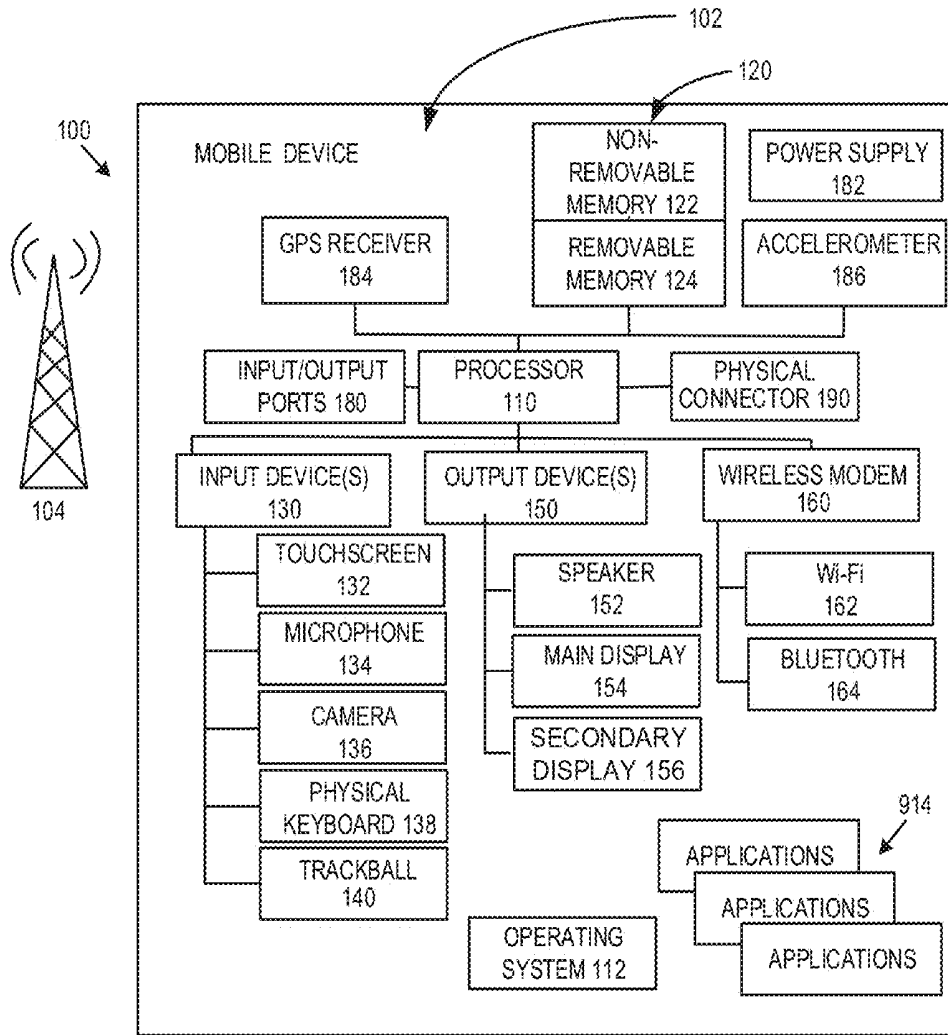

FIG. 17

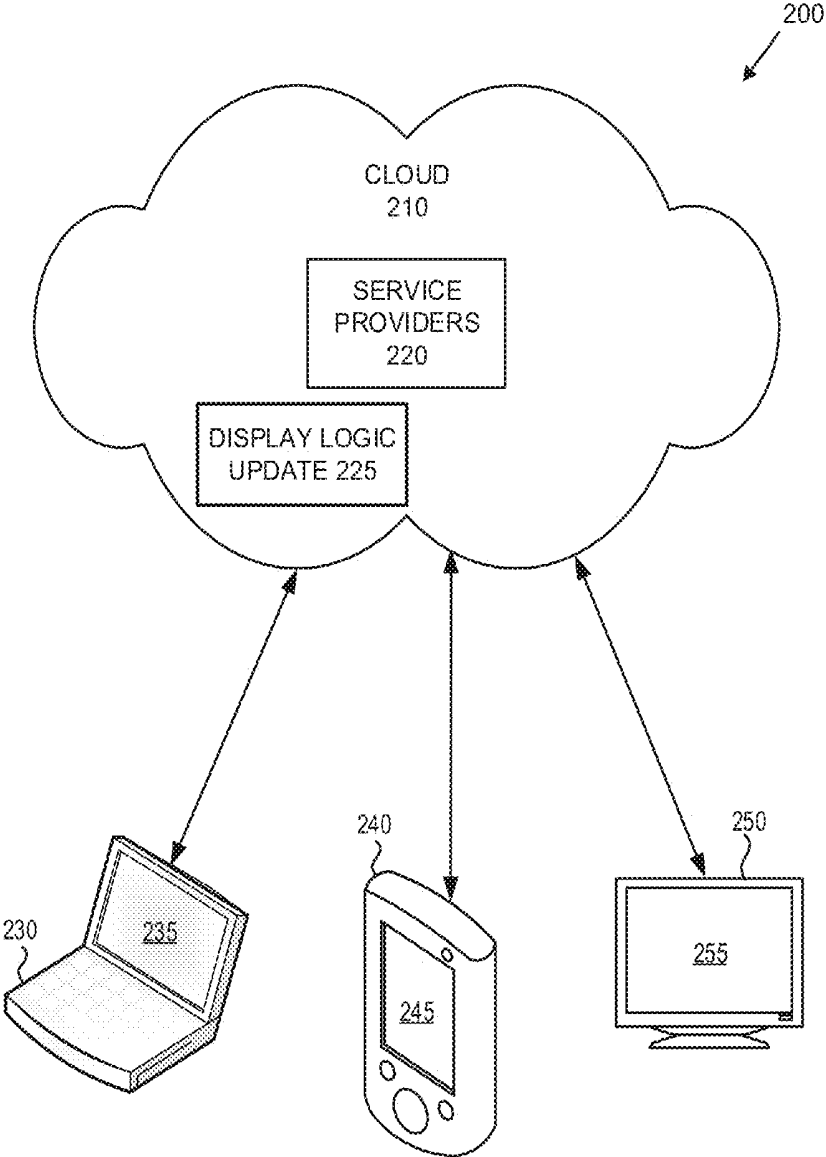
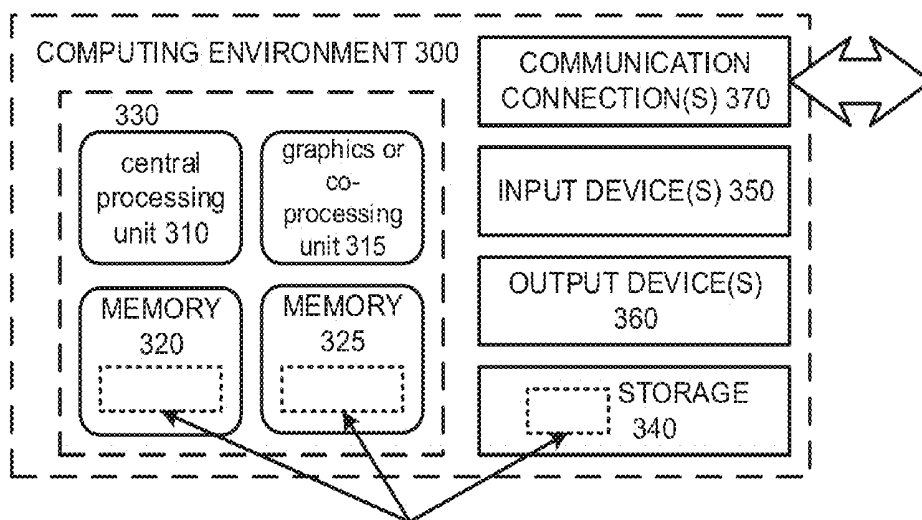

FIG. 18



SOFTWARE 1180 IMPLEMENTING DESCRIBED TECHNOLOGIES

FIG. 19

METHODS FOR PRODUCING A GLASS-BASED NON PLANAR DIGITAL DISPLAY

RELATED APPLICATION

[0001] This application is a continuation of U.S. patent application Ser. No. 13/944,834, filed Jul. 17, 2013, which claims the benefit of U.S. Provisional Patent Application No. 61/823,332 filed May 14, 2013, which are incorporated herein by reference.

BACKGROUND

[0002] Mobile devices having curved, non-planar displays can provide advantages in ergonomics compared to the typical planar displays that are widely used. Display manufacturers have attempted to build non-planar displays using both LCD and OLED technologies. Some have attempted fabricate such displays with glass substrates and others with plastic substrate materials. Manufacturing challenges have prevented mass production to date.

[0003] Early efforts to form curved LCDs faced difficulties with MURA artifacts and luminance nonuniformity. The MURA artifacts arose from bending forces affecting cell gap uniformity in the liquid crystal cell. The luminance non-uniformity resulted from the difficulty in creating curved backlights with suitably uniform backlight distribution.

[0004] OLEDs are not subject to cell gap or backlight concerns, but their stringent requirements for moisture and oxygen barriers present similarly formidable difficulties. Glass fit seals used with glass substrates are a viable barrier solution, but unsuited to curved display applications. Thus, the future for a curved OLED display will likely require specially manufactured plastic substrates. This approach will result in a higher cost of manufacturing and challenges in flexible moisture and oxygen barrier encapsulation.

[0005] Electrophoretic display media is well-adapted to curved devices. This technology is a good fit for e-readers, but its slow switching speed and poor colors make it a weak choice for the competitive mobile device display arena.

[0006] It would be advantageous to provide a non-planar or curved display and associated methods of production that address some of the drawbacks of the currently available technology.

SUMMARY

[0007] Described below are a method of producing a curved display, a curved display and a mobile device having a curved display that address some of the drawbacks of conventional approaches.

[0008] According to a method implementation, a method of producing a curved display for an electronic device comprises providing a substrate comprising a first curvable section comprising at least one flat glass member and a second longitudinally adjacent planar section, placing the curvable section in contact with a member having a curved surface, urging the curvable section towards the curved surface of the member, and maintaining the curvable section in a curved configuration to thereby form the curved display having the adjacent planar section.

[0009] The substrate can comprise a display module in contact with the flat glass member. The second planar section can comprise an operatively connected LED array, and the method can further comprise measuring brightness

across the curvable section of substrate and moving the second planar section relative to the first curvable section to achieve a desired uniformity in measured brightness.

[0010] The member can be a curved cover lens transparent to UV light. Measuring brightness can comprise using a camera directed through the cover lens at the curvable section of the substrate. Maintaining the curved section in the curved configuration can comprise directing UV radiation on the curvable section of the substrate once the desired uniformity in measured brightness is achieved to cure UV sensitive adhesive applied between the curvable section and the curved cover lens.

[0011] Urging the substrate towards the curved surface of the member can comprise pressing an intermediate portion of the curvable section into contact with an aligned intermediate portion of the member and subsequently pressing outer portions of the curvable section on either side of the intermediate portion into contact with aligned outer portions of the member.

[0012] The curved configuration of the curvable section can have a radius of curvature of about 400 mm to about 1000 mm. The flat glass member can have a thickness of about 0.05 mm to about 0.30 mm.

[0013] The flat glass member can be a first flat glass member, and there can be a second flat glass member aligned with the first flat glass member.

[0014] The method can further comprise providing a resilient member in contact with the curvable section and urging the resilient member towards the member by exerting force through the curvable section. The resilient member can comprise closed cell foam.

[0015] The adjacent planar portion can be adapted to receive a circuit component.

[0016] In a method implementation, the at least one flat glass member can be a first flat glass member, the curvable section can comprise UV curable adhesive and a second flat glass member separated from the first flat glass member by a display module, and the method can include subjecting the curvable section to UV radiation, and wherein maintaining the curvable section in the curved configuration comprises removing the curvable section from the member after the UV adhesive has cured. The member can be transparent to UV radiation.

[0017] According to one implementation, a curved display for an electronic device, comprises a substrate comprising a first curved section and a longitudinally adjacent second planar section, the first curved section comprising at least one flat glass member bent into a curved configuration, wherein the second planar section comprises a circuit component mounted to a surface of the planar section.

[0018] The curved display can comprise a curved member attached to one side of the curved section to hold the curved section in the curved configuration. The curved member can be a first curved member, and the curved display can comprise a second curved member attached to an opposite side of the curved section. The first member can comprise a cover lens and the second member can comprise an internal chassis element.

[0019] According to one implementation, a mobile device having a curved display comprises a curved cover lens and a substrate comprising a first curved section and a longitudinally adjacent second planar section. The first curved section comprises an LCD display element having at least one flat glass member bent into a curved configuration to

substantially follow the curvature of curved cover lens. The second planar section comprises an LED array operable to illuminate the LCD display element. The second planar section is movable to adjust uniformity of brightness in the LCD display before the substrate is affixed to the cover lens.

[0020] The first curved section can be adhered to the curved cover lens with a UV curable adhesive. The adhesive can be effective to fill a gap of about 0.02 mm to about 0.10 mm between the substrate and the curved cover lens.

BRIEF DESCRIPTION OF THE DRAWINGS

[0021] FIGS. 1, 2 and 3 are schematic side views of a substrate that includes a display module and a member before, during and after being assembled together into a curved display.

[0022] FIGS. 4, 5 and 6 are schematic side views similar to FIGS. 1, 2 and 3, but showing another implementation of the curved display.

[0023] FIG. 7A is a schematic side view showing another implementation of the curved display.

[0024] FIG. 7B is a schematic side view of a curved display implemented using OLED technology.

[0025] FIGS. 8 and 9 are top plan and side views of another implementation of the components of the curved display.

[0026] FIG. 10 is a schematic side view of the profile of the curved display.

[0027] FIGS. 11, 12 and 13 are schematic side elevation views of a curved display being assembled according to a conventional method.

[0028] FIG. 14 is a schematic side elevation view of the curved display of FIGS. 11-13 being adjusted to increase the uniformity of its brightness.

[0029] FIG. 15 is a schematic side elevation view of a curved display being assembled according to a new method.

[0030] FIG. 16 is a schematic side elevation view of the curved display of FIG. 15 being adjusted automatically to increase the uniformity of its brightness.

[0031] FIG. 17 is a schematic diagram depicting an exemplary mobile device with which any of the disclosed embodiments can be implemented.

[0032] FIG. 18 is a schematic diagram illustrating a generalized example of a suitable implementation environment for any of the disclosed embodiments.

[0033] FIG. 19 is a schematic diagram illustrating a generalized example of a suitable computing environment for any of the disclosed embodiments.

DETAILED DESCRIPTION

[0034] New technology developments in the manufacture of glass sheets and other materials used to make displays have enabled extremely thin sheets to be manufactured, even as thin as 50-300 microns per sheet (0.050 to 0.300 mm).

[0035] For LCD displays, it has been found that displays made using these glass substrates can be bent into 2D curved shapes with bend radius of about 400 mm to about 1000 mm, or even about 200 mm to about 1000 mm, can be achieved without losing functionality. A bend radius in this range enables unique device form factors with advantages in display performance and ergonomics. In addition, such displays can be built inexpensively using existing LCD manufacturing equipment. These glass displays have an inherent optical advantage relative to plastic displays due to

the superior optical properties of glass. These displays can be used in mobile devices to provide better ergonomics, low display power consumption, and a significant cost advantage relative to emerging plastic OLED technology.

[0036] FIGS. 1-3 are schematic views showing important steps of assembling and fabricating a curved display 10. As shown in FIG. 1, at least a first substrate 12 is provided. Typically, each substrate includes at least one glass layer, as well as a display component layer. In the case of the first substrate 12, there is a first glass layer 16 and a thin film transistor layer 18 provided on the first glass layer 16.

[0037] In the example of FIG. 1, there is also a second substrate 14. The second substrate 14 has at least one glass layer, i.e., a second glass layer 20, and a display component layer, e.g., a color filter layer 22, provided on the second glass layer 20. In the illustrated embodiment, the first substrate 12 and the second substrate 14 are positioned on opposite sides of a liquid crystal layer 24. The illustrated configuration of the first and second substrates 12, 14 and the liquid crystal layer sealed between the substrates is also referred to herein as the display module.

[0038] FIG. 1 also shows a support or forming member 26. As will be described in more detail below, the member 26 may be initially planar (FIG. 1 and FIG. 2) before it is formed into a curved configuration, or it may have a curved configuration (FIG. 3) and serve as a form against which the first substrate 12 (or first and second substrates 12, 14) are urged to take on a curved configuration. In FIG. 1 (as well as in FIGS. 2-9), the backlight unit has been omitted for clarity.

[0039] FIG. 2 shows the member 26 and the first and second substrates 12, 14 as assembled in contact with each other. In some implementations, the member 26 is adhered to an adjacent substrate. As illustrated in FIG. 2, the member 26 can be adhered to the second substrate 14. In some implementations, the adhesive is not cured until the components have been shaped into their final form.

[0040] FIG. 3 shows the assembled member 26 and first and second substrates 12, 14 after being formed or bent into a curved configuration to create the curved display 10. In the schematic view of FIG. 3, the resulting curvature is exaggerated for clarity. In the implementation shown in FIG. 3, the member 26 can be maintained as part of the curved display. For example, the member 26 can be a frame member (including a chassis) or a cover lens.

[0041] FIGS. 4, 5 and 6 are schematic views of a curved display 30 that is similar to the curved display 10, except the curved display 30 is formed with two support or fowling members, i.e., the members 26, 28, on its inner and outer sides. In FIG. 5, the members are shown in their assembled condition adjacent the first substrate 12 and the second substrate 14, respectively. As in the above implementation, adhesive may be applied between one or both of the members and the adjacent substrate. In FIG. 6, the assembly of the members 26, 28 and the substrates 12, 14 is shown after it has been deformed or bent into a curved configuration to create the curved display 30.

[0042] In the implementation shown in FIG. 6, the members 26, 28 can be maintained as part of the curved display, or different curved members could be substituted. For example, one of the members could be a cover lens and the other of the members could be a frame member (e.g., chassis). For a concave display, the member 28 could be configured as a cover lens (or other intermediate component

on the working side of the display), and the member 26 could be configured as a frame component or other internal component.

[0043] FIG. 7A is a schematic view of another implementation in which a curved display module 40 does not have any supporting members. Thus, it is at least one curved substrate that provides the curved configuration in the resulting curved display module. More specifically, in the implementation of FIG. 7A, it is the first substrate 12 and the second substrate 14 that together define the curved display module 40. Each substrate is formed in a curved shape, such as by using a curved member, and then an assembly of both completed substrates with the liquid crystal material sealed between the substrates is produced. The curved display module 40 can be used with a curved cover lens, or, in some cases with a planar cover lens that is urged into a curved shape by the display module.

[0044] FIG. 7B is a schematic side view of an implementation of a curved display formed with OLED technology. Some available OLEDs have polyimide substrates and flexible encapsulation, so they can experience more shear stress without failure than more conventional OLEDs having a frit edge seal, but currently only lower yields of such OLEDs are possible.

[0045] The OLED curved display of FIG. 7B, which is shown during assembly and before being shaped into the final curved configuration, however, has a glass TFT array backplane topped with flexible encapsulant. This configuration serves to both reduce the overall cost and yield losses associated with debonding plastic substrates while at the same time overcoming the fragility of glass frit seals.

[0046] As shown, there is a display backplane 90, which is comprised of a thin glass substrate 92 and a TFT array 94 and its associated circuitry. A stack of OLED materials 96 is positioned adjacent the TFT array 94. An encapsulating layer or moisture and oxygen barrier 98, which can be formed of alternating layers of organic and inorganic materials, is provided over the stack of OLED materials 96. In a subsequent step, the intermediate assembly on the left is assembled together with a cover lens (or other shaping structure), which is represented at 99 on the right side and before it has been formed to have a curved configuration.

[0047] FIGS. 8 and 9 are top plan and side elevation views, respectively, of a curved display 50 according to another embodiment. As shown in FIG. 8, there is a first substrate 44 (sometimes referred to as a "top glass") that is aligned with and adjacent a second substrate 42 (sometimes referred to as a "bottom glass"), which together form a sandwich construction with a liquid crystal layer 43 between the substrates 44, 42.

[0048] One of the substrates has an extended portion for mounting a display ASIC or circuit component 52. As shown, the second substrate 42 has an extended portion that provides a space to mount the display circuit component 53. In some implementations, the curved display 50 can be formed such that there is a planar extended section 46 extending from a remaining portion 48 that is free to be formed into the curved configuration as shown in the schematic side view of FIG. 10. In this way, the planar section 46 provides for secure mounting of the display circuit component 52 and reliable electrical connections without requiring changes to the display circuit component 52, which can have a conventional configuration. Any supporting structure, such as a fixture or frame member, can also be

formed to have a corresponding planar section to support the planar section 46. In other implementations, the substrate is continuously and more moderately curved such that die bonding or other operations to attach the circuit component 52 can be completed without providing a separate planar section.

[0049] As described above, the display can be fabricated to have a curved configuration. In some implementations, adhesive is applied between various components and they are then formed into the curved configuration before the adhesive is cured. For example, in implementations with two substrates, a UV-curable adhesive can be applied between the substrates while they are in their substantially planar state. The assembly is then formed into the curved configuration, and the adhesive is cured, which tends to make the pressure between the substrates more even and avoid shearing among the individual layers.

[0050] To implement these techniques for production, it may be advantageous to have the motherglass substrates singulated prior to cell assembly and then cleaned and dried prior to receiving any adhesive or epoxy. Conventional epoxy dispensers may need to be reconfigured to apply epoxy to substrates that have already been singulated. In some implementations, the epoxied assemblies are supported in curved fixtures until the epoxy is sufficiently cured. It can be advantageous to make the fixtures transparent to UV light such that the curing can take place while the substrates are held in the fixtures. In some implementations, the fixtures are then removed.

[0051] As also described above, once the substrate(s) has been bent or formed into the curved configuration, it can be secured to a curved element or member that remains in place in the final curved display. For example, the curved element or member can support the front side of the curved display, which may comprise the display element, touch layers and cover glass, which may be laminated together. This curved element can be designed, e.g., as a cover lens in a predefined curved shape, such as a curved cover lens molded of glass. A different curved element or member can be provided to support the rear side of the display or its frame, such as through the reflector and light guide, which may be laminated together. The curved element for the rear side can be configured as a frame element, chassis or other internal component. The various components can be held in their desired positions to create the curved configuration by using suitable mechanical fastening arrangements. Maintaining uniform pressure over the full extent of the display results in better performance.

[0052] As indicated, adhesive is used between some of the components in some implementations. In some implementations, a resulting layer of adhesive can be thicker, such as if the cover lens has topology because a touchscreen is formed on its inner surface. Thus, the adhesive layer(s) can be effective to fill gaps of about 0.02 mm to about 0.09 mm.

[0053] Also, one or more layers of foam or other resilient material can be introduced into the assembly to assist in making the pressure exerted on the substrate(s) more even. For example, closed cell foam installed over an inner side member or chassis allows for better assembly of the substrate onto the inner side member because the foam deforms slightly as required to even out slight deformities in the substrate or the member and prevents too much pressure from being applied to the display element.

[0054] FIGS. 11-16 depict another example of a curved display and assembly methods suitable for production. FIGS. 11-13 are schematic side elevation views of a curved display 60 being assembled. As shown in FIG. 11, a display component 62 is aligned with a cover lens 64, and adhesive 66 is applied between these elements. The display component 62 can be a LCD display component that is capable of operating after being slightly bent or deformed from a planar configuration as shown in FIG. 11 into a curved configuration (e.g., as shown in FIG. 12). Specifically, the display component 62 has one or more substrates having a curvable section 68 and a longitudinally adjacent planar section 70, such as is described above in FIG. 10. An LED array 72 is mounted on the planar section 70 at a position slightly spaced from the end of the curvable section 68. The LED array 72 serves to illuminate the display component 62, as indicated by the triangular schematic illumination cone 74.

[0055] As indicated in FIG. 12, clamping force is applied to the cover lens 64 and the display component 62 (either directly or indirectly) to cause the curvable section 68 to deform as desired to generally follow the cover lens 64 and promote good adhesion between the cover lens 64 and the curvable section 68. In FIG. 13, a source of UV light 76 is directed onto the adhesive through the cover lens 64 to cure the adhesive. In FIG. 14, after the adhesive is cured, the performance of the display component 62 is evaluated. In particular, the LED array is connected so that it can provide illumination throughout the display component, and the resulting brightness is checked. As indicated schematically by the arrows, a display component with less than desired uniformity of brightness will have noticeable bright spots and dark spots.

[0056] It has been discovered that the uniformity of brightness in the display component 62 can be adjusted to an acceptable degree in many circumstances by moving the planar section 70. As shown in FIG. 14, a force can be applied, e.g., to urge the LED 72 array/end of the planar section 70 to rotate very slightly in one direction or the other, thus causing the coupling with the attached curvable section 68 to deform slightly and thus change the brightness of the display. When the adjustment takes place after the adhesive has cured, however, it must be done delicately and typically in a manual fashion. Also, it can be difficult to retain the display component in its adjusted position when the applied force is removed once the adhesive is already cured.

[0057] FIGS. 15 and 16 are schematic side elevation views of the curved display 60 being assembled according to another method. In FIG. 15, a camera 78 is focused on the cover lens 64 and the display component 62 to measure changes in the brightness of the display component. The display component 62 in this example has an array of backlight LEDs. After the display component 62 and the cover lens are clamped together, but before the adhesive is cured, the display component's backlight LEDs are illuminated and the camera records the displayed brightness pattern. The brightness pattern information is processed to determine if it is acceptably uniform. If not, a program automatically controls a pair of actuators 80 to move the planar section 70 and the brightness uniformity is evaluated again. This process is continued until a best possible brightness uniformity is achieved, such as by using a feedback loop. Optionally, the process can also be ended after a predetermined time or number of cycles. Once the adjustment process is complete, the program controls the source of

UV radiation to emit UV light as shown in FIG. 16 to cure the adhesive and thus secure the assembly together with the curvable section 68 in the adjusted position. In this way, a relatively low cost curved display is achieved from a standard display component that is bent into a curved configuration, automatically adjusted to have acceptable brightness uniformity and then secured in the adjusted position.

[0058] In implementations where one or more substrates are bent or formed into the curved configuration, using very thin glass layers (including TFT and CT layers) that are sealed when in their planar configurations makes fabrication possible using existing liquid crystal assembly equipment. Some sheering may take place in and among the various layers of the curved display as formed, but the display remains highly functional and the sheering may not be noticeable to the user.

[0059] Any light guide present in the curved display can be adapted as appropriate for the curved configuration. For example, the light guide can be modified as necessary to provide for more even distribution of light from the back-light throughout the display. In some implementations, the light guide can be provided with a new pattern of surface features designed to reduce light loss due to exit angle changes resulting from the curved configuration. In some implementations, optical modeling software can be used instead of or in conjunction with changes to the light guide and other similar elements to ensure adequate illumination uniformity and optical properties in the curved display.

[0060] The curved display format provides many advantages. In implementations of a concave display, a user-facing camera on the curved display is pointed slightly down (or slightly up) and thus is more direct pointed at the user in most circumstances compared to such a camera on a flat display, which often tends to be pointing above or below the user's face. Having a user-facing camera that more naturally captures the face is advantageous in applications that use the camera, such as two-way video calling.

[0061] The curved display also improves some detection operations. For example, a detector grid in a curved display configured to detect finger height and angle of approach has better performance than a similar grid in a flat display because of the geometry of the concave display. In an implementation with a hover touch detector grid that detects finger height and angle of approach by relative signal strength, the detectors in a curved display have greater signal strength when the finger is very close to the display and thus exhibit better performance.

[0062] As described above, a flat substrate (or display module comprising flat substrates) can be formed into a curved shape (1) by being placed between a curved cover lens and a curved internal member such as a chassis, (2) by being urged, together with a flat cover lens, over a curved internal member or chassis and then formed to the curve configuration or (3) by being urged into a curved cover lens, thereby creating a curved display. As also described, the curved display can be achieved by using a curved display module formed from substrates that are formed to have a curved configuration, and then fitting the curved display module in a curved cover lens or using the curved display module to form a flat cover lens into a curved cover lens as assembled.

[0063] FIG. 17 is a system diagram depicting an exemplary mobile device 100 including a variety of optional hardware and software components, shown generally at 102.

Any components **102** in the mobile device can communicate with any other component, although not all connections are shown, for ease of illustration. The mobile device can be any of a variety of computing devices (e.g., cell phone, smartphone, handheld computer, Personal Digital Assistant (PDA), etc.) and can allow wireless two-way communications with one or more mobile communications networks **104**, such as a cellular or satellite network.

[0064] The illustrated mobile device **100** can include a controller or processor **110** (e.g., signal processor, micro-processor, ASIC, or other control and processing logic circuitry) for performing such tasks as signal coding, data processing, input/output processing, power control, and/or other functions. An operating system **112** can control the allocation and usage of the components **102** and support for one or more application programs **114**. The application programs can include common mobile computing applications (e.g., email applications, calendars, contact managers, web browsers, messaging applications), or any other computing application. Functionality **113** for accessing an application store can also be used for acquiring and updating applications **114**.

[0065] The illustrated mobile device **100** can include memory **120**. Memory **120** can include non-removable memory **122** and/or removable memory **124**. The non-removable memory **122** can include RAM, ROM, flash memory, a hard disk, or other well-known memory storage technologies. The removable memory **124** can include flash memory or a Subscriber Identity Module (SIM) card, which is well known in GSM communication systems, or other well-known memory storage technologies, such as “smart cards.” The memory **120** can be used for storing data and/or code for running the operating system **112** and the applications **114**. Example data can include web pages, text, images, sound files, video data, or other data sets to be sent to and/or received from one or more network servers or other devices via one or more wired or wireless networks. The memory **120** can be used to store a subscriber identifier, such as an International Mobile Subscriber Identity (IMSI), and an equipment identifier, such as an international Mobile Equipment Identifier (IMEI). Such identifiers can be transmitted to a network server to identify users and equipment.

[0066] The mobile device **100** can support one or more input devices **130**, such as a touchscreen **132**, microphone **134**, camera **136**, physical keyboard **138** and/or trackball **140** and one or more output devices **150**, such as a speaker **152**, a main display **154**, and/or one or more secondary displays **156**. Other possible output devices (not shown) can include piezoelectric or other haptic output devices. Some devices can serve more than one input/output function. For example, touchscreen **132** and displays **154**, **156** can be combined in a single input/output device. The input devices **130** can include a Natural User Interface (NUI). An NUI is any interface technology that enables a user to interact with a device in a “natural” manner, free from artificial constraints imposed by input devices such as mice, keyboards, remote controls, and the like. Examples of NUI methods include those relying on speech recognition, touch and stylus recognition, gesture recognition both on screen and adjacent to the screen, air gestures, head and eye tracking, voice and speech, vision, touch, gestures, and machine intelligence. Other examples of a NUI include motion gesture detection using accelerometers/gyroscopes, facial recognition, 3D displays, head, eye, and gaze tracking, immer-

sive augmented reality and virtual reality systems, all of which provide a more natural interface, as well as technologies for sensing brain activity using electric field sensing electrodes (EEG and related methods). Thus, in one specific example, the operating system **112** or applications **114** can comprise speech-recognition software as part of a voice user interface that allows a user to operate the device **100** via voice commands. Further, the device **100** can comprise input devices and software that allows for user interaction via a user’s spatial gestures, such as detecting and interpreting gestures to provide input to a gaming application.

[0067] A wireless modem **160** can be coupled to an antenna (not shown) and can support two-way communications between the processor **110** and external devices, as is well understood in the art. The modem **160** is shown generically and can include a cellular modem for communicating with the mobile communication network **104** and/or other radio-based modems (e.g., Bluetooth **164** or Wi-Fi **162**). The wireless modem **160** is typically configured for communication with one or more cellular networks, such as a GSM network for data and voice communications within a single cellular network, between cellular networks, or between the mobile device and a public switched telephone network (PSTN).

[0068] The mobile device can further include at least one input/output port **180**, a power supply **182**, a satellite navigation system receiver **184**, such as a Global Positioning System (GPS) receiver, an accelerometer **186**, and/or a physical connector **190**, which can be a USB port, IEEE 1394 (FireWire) port, and/or RS-232 port. The illustrated components **102** are not required or all-inclusive, as any components can be deleted and other components can be added.

[0069] FIG. **18** illustrates a generalized example of a suitable implementation environment **200** in which described embodiments, techniques, and technologies may be implemented.

[0070] In example environment **200**, various types of services (e.g., computing services) are provided by a cloud **210**. For example, the cloud **210** can comprise a collection of computing devices, which may be located centrally or distributed, that provide cloud-based services to various types of users and devices connected via a network such as the Internet. The implementation environment **200** can be used in different ways to accomplish computing tasks. For example, some tasks (e.g., processing user input and presenting a user interface) can be performed on local computing devices (e.g., connected devices **230**, **240**, **250**) while other tasks (e.g., storage of data to be used in subsequent processing) can be performed in the cloud **210**.

[0071] In example environment **200**, the cloud **210** provides services for connected devices **230**, **240**, **250** with a variety of screen capabilities. Connected device **230** represents a device with a computer screen **235** (e.g., a mid-size screen). For example, connected device **230** could be a personal computer such as desktop computer, laptop, notebook, netbook, or the like. Connected device **240** represents a device with a mobile device screen **245** (e.g., a small size screen). For example, connected device **240** could be a mobile phone, smart phone, personal digital assistant, tablet computer, or the like. Connected device **250** represents a device with a large screen **255**. For example, connected device **250** could be a television screen (e.g., a smart television) or another device connected to a television (e.g.,

a set-top box or gaming console) or the like. One or more of the connected devices **230, 240, 250** can include touchscreen capabilities. Touchscreens can accept input in different ways. For example, capacitive touchscreens detect touch input when an object (e.g., a fingertip or stylus) distorts or interrupts an electrical current running across the surface. As another example, touchscreens can use optical sensors to detect touch input when beams from the optical sensors are interrupted. Physical contact with the surface of the screen is not necessary for input to be detected by some touchscreens. Devices without screen capabilities also can be used in example environment **200**. For example, the cloud **210** can provide services for one or more computers (e.g., server computers) without displays.

[0072] Services can be provided by the cloud **210** through service providers **220**, or through other providers of online services (not depicted). For example, cloud services can be customized to the screen size, display capability, and/or touch screen capability of a particular connected device (e.g., connected devices **230, 240, 250**). In some embodiments, connected devices having more than one display can communicate with the cloud **210** to receive updates **225** and/or changes to their display logic, such as the change way in which the different screens are used to perform various functions.

[0073] In example environment **200**, the cloud **210** provides the technologies and solutions described herein to the various connected devices **230, 240, 250** using, at least in part, the service providers **220**. For example, the service providers **220** can provide a centralized solution for various cloud-based services. The service providers **220** can manage service subscriptions for users and/or devices (e.g., for the connected devices **230, 240, 250** and/or their respective users).

[0074] FIG. **19** depicts a generalized example of a suitable computing environment **300** in which the described innovations may be implemented. The computing environment **300** is not intended to suggest any limitation as to scope of use or functionality, as the innovations may be implemented in diverse general-purpose or special-purpose computing systems. For example, the computing environment **300** can be any of a variety of computing devices (e.g., desktop computer, laptop computer, server computer, tablet computer, media player, gaming system, mobile device, etc.)

[0075] With reference to FIG. **13**, the computing environment **300** includes one or more processing units **310, 315** and memory **320, 325**. In FIG. **3**, this basic configuration **330** is included within a dashed line. The processing units **310, 315** execute computer-executable instructions. A processing unit can be a general-purpose central processing unit (CPU), a graphics processing unit (GPU), a processor in an application-specific integrated circuit (ASIC), or any other type of processor. In a multi-processing system, multiple processing units execute computer-executable instructions to increase processing power. For example, FIG. **19** shows a central processing unit **310** as well as a graphics processing unit or co-processing unit **315**. The tangible memory **320, 325** may be volatile memory (e.g., registers, cache, RAM), non-volatile memory (e.g., ROM, EEPROM, flash memory, etc.), or some combination of the two, accessible by the processing unit(s). The memory **320, 325** stores software **380** implementing one or more innovations described herein, in the form of computer-executable instructions suitable for execution by the processing unit(s).

[0076] A computing system may have additional features. For example, the computing environment **300** includes storage **340**, one or more input devices **350**, one or more output devices **360**, and one or more communication connections **370**. An interconnection mechanism (not shown) such as a bus, controller, or network interconnects the components of the computing environment **300**. Typically, operating system software (not shown) provides an operating environment for other software executing in the computing environment **300**, and coordinates activities of the components of the computing environment **300**.

[0077] The tangible storage **340** may be removable or non-removable, and includes magnetic disks, magnetic tapes or cassettes, CD-ROMs, DVDs, or any other storage device which can be used to store information and which can be accessed within the computing environment **300**. The storage **340** stores instructions for the software **380** implementing one or more innovations described herein.

[0078] The input device(s) **350** may be a touch input device such as a touchscreen, keyboard, mouse, pen, or trackball, a voice input device, a scanning device, or another device that provides input to the computing environment **300**. For video encoding, the input device(s) **350** may be a camera, video card, TV tuner card, or similar device that accepts video input in analog or digital form, or a CD-ROM or CD-RW that reads video samples into the computing environment **300**. The output device(s) **360** may be one or more displays, printer, speaker, CD-writer, or another device that provides output from the computing environment **300**.

[0079] The communication connection(s) **370** enable communication over a communication medium to another computing entity. The communication medium conveys information such as computer-executable instructions, audio or video input or output, or other data in a modulated data signal. A modulated data signal is a signal that has one or more of its characteristics set or changed in such a manner as to encode information in the signal. By way of example, and not limitation, communication media can use an electrical, optical, RF, or other carrier.

[0080] Although the operations of some of the disclosed methods are described in a particular, sequential order for convenient presentation, it should be understood that this manner of description encompasses rearrangement, unless a particular ordering is required by specific language set forth below. For example, operations described sequentially may in some cases be rearranged or performed concurrently. Moreover, for the sake of simplicity, the attached figures may not show the various ways in which the disclosed methods can be used in conjunction with other methods.

[0081] Any of the disclosed methods can be implemented as computer-executable instructions stored on one or more computer-readable storage media (e.g., one or more optical media discs, volatile memory components (such as DRAM or SRAM), or nonvolatile memory components (such as flash memory or hard drives)) and executed on a computer (e.g., any commercially available computer, including smart phones, tablets, or other mobile devices that include computing hardware). As should be readily understood, the term computer-readable storage media does not include communication connections, such as modulated data signals. Any of the computer-executable instructions for implementing the disclosed techniques as well as any data created and used during implementation of the disclosed embodiments can be stored on one or more computer-readable media (which

excludes propagated signals). The computer-executable instructions can be part of, for example, a dedicated software application or a software application that is accessed or downloaded via a web browser or other software application (such as a remote computing application). Such software can be executed, for example, on a single local computer (e.g., any suitable commercially available computer) or in a network environment (e.g., via the Internet, a wide-area network, a local-area network, a client-server network (such as a cloud computing network), or other such network) using one or more network computers.

[0082] For clarity, only certain selected aspects of the software-based implementations are described. Other details that are well known in the art are omitted. For example, it should be understood that the disclosed technology is not limited to any specific computer language or program. Certain details of suitable computers and hardware are well known and need not be set forth in detail in this disclosure.

[0083] It should also be well understood that any functionality described herein can be performed, at least in part, by one or more hardware logic components, instead of software. For example, and without limitation, illustrative types of hardware logic components that can be used include Field-programmable Gate Arrays (FPGAs), Program-specific Integrated Circuits (ASICs), Program-specific Standard Products (ASSPs), System-on-a-chip systems (SOCs), Complex Programmable Logic Devices (CPLDs), etc.

[0084] Furthermore, any of the software-based embodiments (comprising, for example, computer-executable instructions for causing a computer to perform any of the disclosed methods) can be uploaded, downloaded, or remotely accessed through a suitable communication means. Such suitable communication means include, for example, the Internet, the World Wide Web, an intranet, software applications, cable (including fiber optic cable), magnetic communications, electromagnetic communications (including RF, microwave, and infrared communications), electronic communications, or other such communication means.

[0085] The disclosed methods, apparatus, and systems should not be construed as limiting in any way. Instead, the present disclosure is directed toward all novel and nonobvious features and aspects of the various disclosed embodiments, alone and in various combinations and subcombinations with one another. The disclosed methods, apparatus, and systems are not limited to any specific aspect or feature or combination thereof, nor do the disclosed embodiments require that any one or more specific advantages be present or problems be solved.

[0086] In view of the many possible embodiments to which the principles disclosed herein may be applied, it should be recognized that the illustrated embodiments are

only preferred examples and should not be taken as limiting the scope of the disclosure. Rather, the scope of the disclosure is defined by the following claims. We therefore claim all that comes within the scope of these claims.

We claim:

1. A curved display for an electronic device, comprising:
 - a main substrate comprising a first curved section extending from a first end of the main substrate and a longitudinally adjacent second planar section extending to define a second end of the main substrate opposite the first end, wherein the first curved section comprises at least one flat glass member bent into a curved configuration, and wherein the second planar section comprises a flat segment of the flat glass member;
 - a display circuit component mounted to an upper surface of the second planar section, the display circuit component being positioned within and spaced from edges of the second planar section;
 - an OLED stack positioned over the first curved section;
 - a secondary substrate comprising a flat glass member bent into a curved configuration and secured to the first curved section of the main substrate with the OLED stack positioned between the first curved section of the main substrate and the secondary substrate.
2. The curved display of claim 1, wherein the secondary substrate is a top glass and the main substrate is a bottom glass.
3. The curved display of claim 1, wherein the secondary substrate is adhered to the first curved section of the main substrate with a UV curable adhesive.
4. The curved display of claim 1, wherein the adhesive is effective to fill a gap of 0.02 mm to 0.10 mm between the secondary substrate and the first curved section of the main substrate.
5. The curved display of claim 1, wherein the display circuit component comprises a display ASIC.
6. The curved display of claim 1, further comprising a resilient member positioned between the secondary substrate and the main substrate.
7. The curved display of claim 1, wherein the curved configuration of first curved section of the first substrate has a radius of curvature of about 200 mm to about 1000 mm.
8. The curved display of claim 1, wherein the fiat glass member of at least one of the main substrate and the secondary substrate has a thickness of about 0.05 mm to about 0.30 mm.
9. The curved display of claim 1, wherein the OLED stack comprises multiple layers.
10. The curved display of claim 1, further comprising an encapsulating layer positioned to encapsulate at least the OLED stack.

* * * * *

专利名称(译)	制造玻璃基非平面数字显示器的方法		
公开(公告)号	US20170041990A1	公开(公告)日	2017-02-09
申请号	US15/277775	申请日	2016-09-27
[标]申请(专利权)人(译)	微软技术许可有限责任公司		
申请(专利权)人(译)	微软技术Licensing, LLC公司		
当前申请(专利权)人(译)	微软技术Licensing, LLC公司		
[标]发明人	TAYLOR JOSEPH BELL CYNTHIA SUE FLECK ROD G MOGHE KSHITIJ OBRIEN PAUL		
发明人	TAYLOR, JOSEPH BELL, CYNTHIA SUE FLECK, ROD G. MOGHE, KSHITIJ O'BRIEN, PAUL		
IPC分类号	H05B33/04 H01L51/52 H01L51/00 H05B33/08 H01L27/32		
CPC分类号	H05B33/04 H05B33/0896 H01L27/3251 H01L51/0096 G02F2202/28 G02F1/1339 G02F1/133308 G02F2001/133331 H01L51/5237 G02F1/1333 G02F2001/133325 G02F2001/133388 H05B45/60		
优先权	61/823332 2013-05-14 US		
其他公开文献	US9992825		
外部链接	Espacenet USPTO		

摘要(译)

一种用于电子设备的弯曲显示器，包括主基板，显示电路组件，OLED堆叠和辅助基板。主基板具有从主基板的第一端延伸的第一弯曲部分和纵向相邻的第二平面部分，第二平面部分延伸以限定主基板的与第一端相对的第二端。第一弯曲部分包括至少一个弯曲成弯曲构型的平板玻璃构件，第二平面部分包括平板玻璃构件的平坦部分。显示电路元件安装在第二平面部分的上表面上，显示电路元件位于第二平面部分的边缘内并与其隔开。OLED堆叠定位在第一弯曲部分上方。辅助基板包括弯曲成弯曲构造并固定到主基板的第一弯曲部分的平板玻璃构件，其中OLED堆叠位于主基板的第一弯曲部分和第二基板之间。

